

ELEGOO ▶▶ Create the Future 

Centauri Carbon 2 Combo

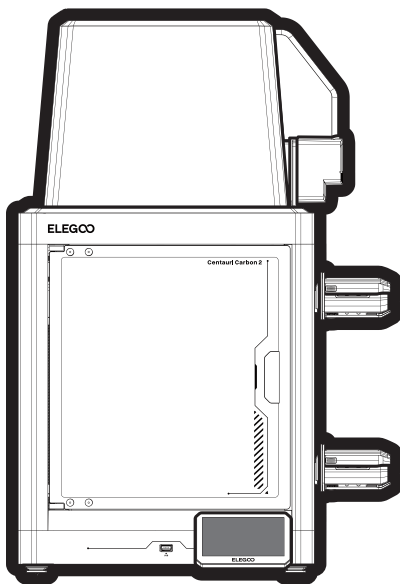

▶ **User Manual** 

 Check the included USB flash drive for a step-by-step installation video.

 **V2.1**

Thank You for Choosing
▶▶▶ the ELEGOO Product!

ELEGOO

Upon receiving your product, please check that the device is in good condition and all accessories are included. If you encounter any issues during installation, operation, or maintenance, please contact the ELEGOO after-sales team through the official channels below for professional support:

VISIT OUR
OFFICIAL SUPPORT PAGE



Scan the QR code for
one-on-one assistance

<https://www.elegoo.com/pages/contact-support>
(We recommend copying the link and opening it in your browser.)

UNLOCK INFINITE
FREE MODELS

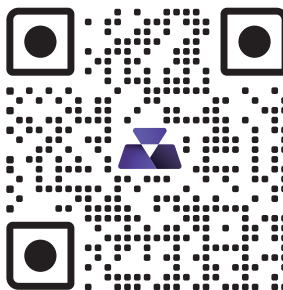

Scan the QR code to explore Nexprint and
download free models for easy,
one-click printing.

<https://www.nexprint.com/?got=IN>

Note: To ensure optimal performance, each ELEGOO product undergoes rigorous printing tests before shipping. Minor surface scratches may be visible upon delivery; this is normal and will not affect functionality.

Important Notes

- ▶ Do not place the printer in a highly vibrating or unstable environment, as machine vibrations can affect print quality.
 - ▶ Do not touch the nozzle or heated bed while the printer is in operation to avoid burns and personal injury from high temperatures.
 - ▶ After printing, promptly utilize the residual heat in the nozzle to effectively clean the filament residue using a suitable tool. Avoid direct contact with the nozzle to prevent potential burns.
 - ▶ We recommend using ELEGOO's slicing software to ensure the proper functioning of the machine and achieve optimal printing results.
 - ▶ Perform regular maintenance on the printer by cleaning the machine body with a dry cloth to remove dust and any sticky filament residue. Ensure the printer is powered off before cleaning.
 - ▶ Regularly inspect and clean the printer's cooling fans to prevent dust buildup, ensuring optimal performance and extended service life.
 - ▶ Be cautious of the machine's high-speed moving parts to avoid any potential pinch hazards.
 - ▶ The Z-axis of the machine utilizes lead screws for its moving parts. Apply lubricating oil as needed to ensure smooth movement.
 - ▶ Children must be supervised by adults when using the machine to avoid personal injury.
 - ▶ In case of an emergency, directly turn off the power.
 - ▶ Ensure the machine is properly grounded for safe operation. Failure to properly ground or neglecting to ground the machine can increase the risk of electrical leakage.
 - ▶ If the machine is not in use for an extended period, please turn off the power and unplug the power cord.
-

Contents ELEGOO

▶ Machine Specifications	01
▶ Printer Component Introduction	02
▶ CANVAS Component Introduction	04
▶ Included Accessories	05
▶ Tool Kit	06
▶ Unpacking	07
▶ Printer Installation	08
▶ CANVAS Installation	09
▶ Filament Loading	12
▶ First Print	15
▶ ElegooSlicer	16
▶ LAN (Network) Printing	19
▶ Mainboard Connections	21

Machine Specifications

Printing Specifications

Printing Technology: Fused Deposition Modeling(FDM)

Build Volume: 256 × 256 × 256 mm

Printing Accuracy: ± 0.1 mm

Nozzle Diameter: 0.4 mm

Printing Speed: ≤ 500 mm/s

Ambient Temperature: 5-40 °C

Electrical Requirements

Input Voltage: 100-240 VAC, 50/60 Hz

Rated Power: 1100 W@220 V / 350 W@110 V

Temperature Specifications

Max Nozzle Temperature: 350 °C

Max Heated Bed Temperature: 110 °C

Software Specifications

Slicer Software: ElegooSlicer (Recommended)

Input File Format: STL, OBJ, 3MF, STEP

Output File Format: G-code

Connectivity: USB Flash Drive, Wi-Fi

Physical Specifications

Machine Size: 500 × 480 × 743 mm

Net Weight: 19.35 kg

Printer Component Introduction

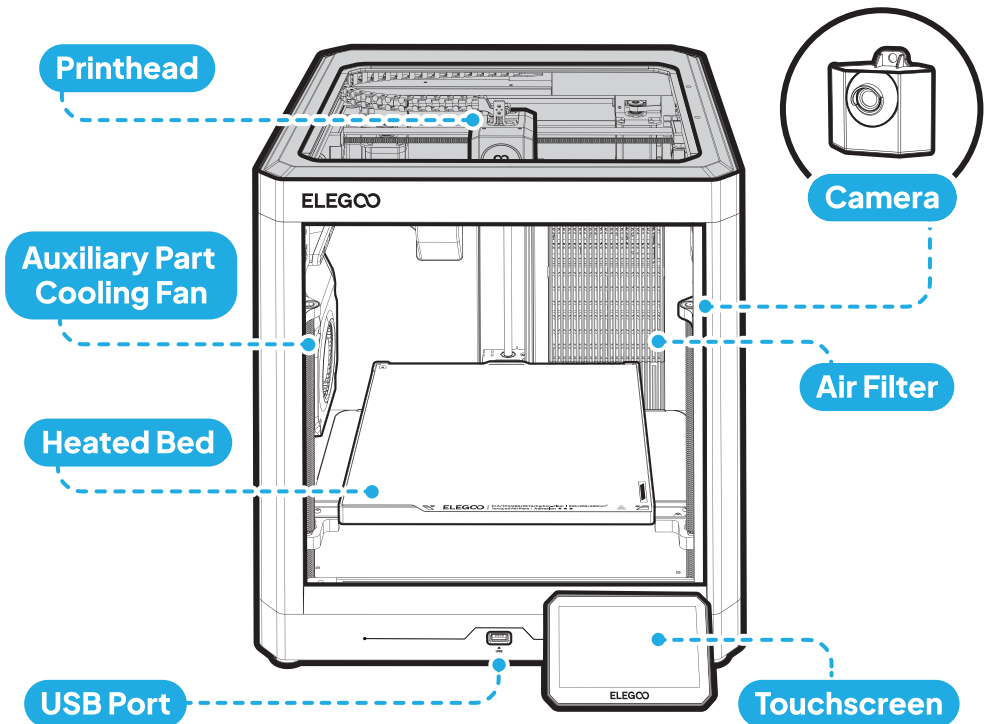

Printer Component Introduction

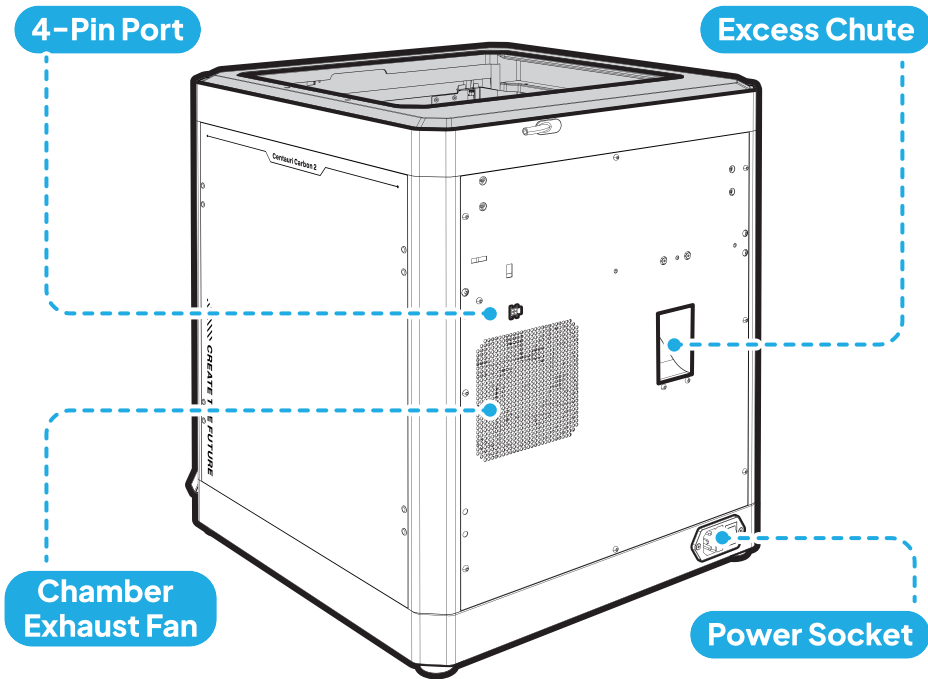

CANVAS Component Introduction

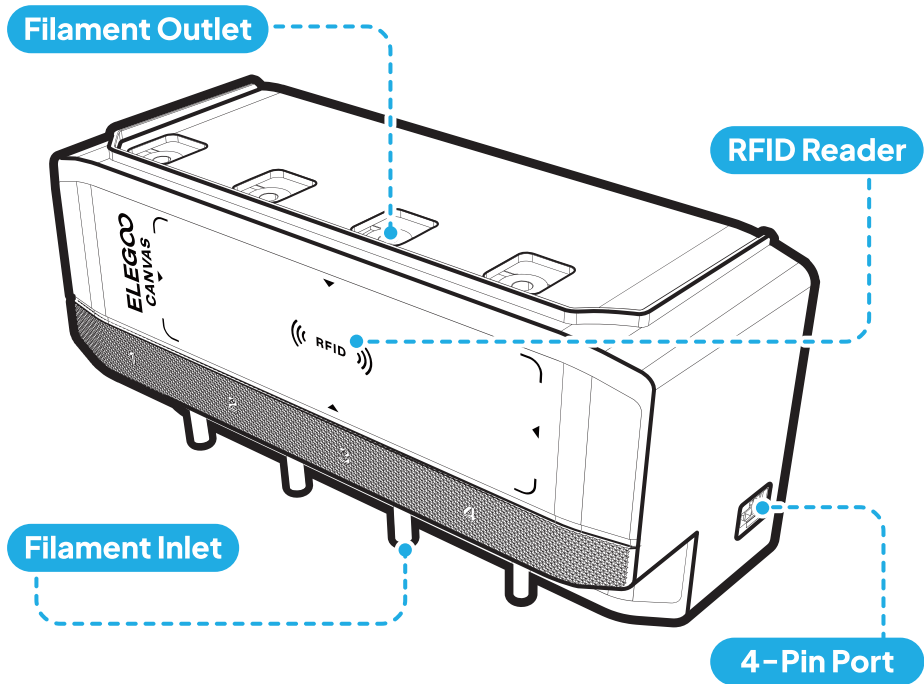

Included Accessories



Touchscreen



Nozzle Wiper
Assembly



Power
Cord



4-Pin Cable



Spool Holder Module x4
(2 Left, 2 Right)



Filament Hub



CANVAS Mounting
Bracket



Thermal
Cover



User
Manual

Tool Kit

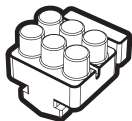

Spare Nozzle
Wiper



USB Flash Drive



Scraper
Blade



Unclogging Pin



(1.5/2.0/2.5/3.0 mm)
Allen Key



Screwdriver



Filament
Sample

■ Screws for Different Accessories ▶▶▶



PM3×8 (×3)
CANVAS Feeding Module



PM3×12 (×8)
Spool Holder



FM3×12 (×2)
Nozzle Wiper Assembly



PA3×10 (×2)
Scraper Blade



PM3×6 (×2)
Filament Hub



PM3×50 (×2)
CANVAS Mounting Bracket



PM3×4 (×2)
Nozzle Wiper Assembly

Unpacking



▶ Scan the QR code to watch the tutorial ◀

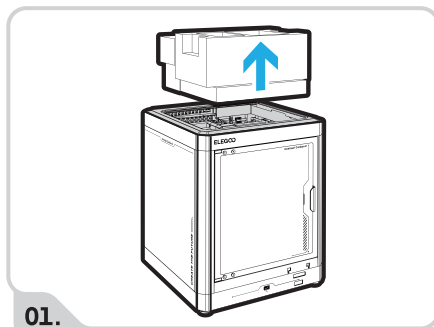

01.

Take out the foam, touchscreen, and toolbox from the printer.

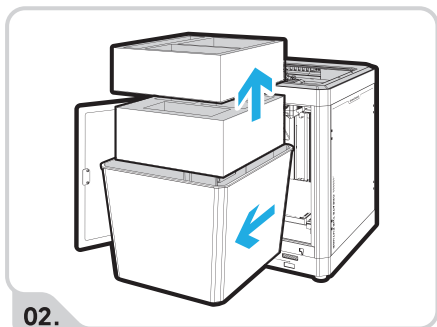

02.

Open the glass door and take out the thermal cover. Then, remove the foam, nozzle wiper assembly, and CANVAS module inside the thermal cover.

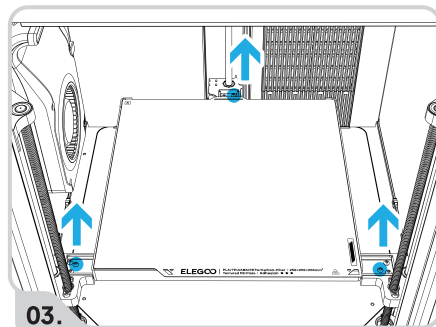

03.

Use the 2.5 mm Allen key to remove the 3 screws marked in blue to unlock the heated bed.

Printer Installation

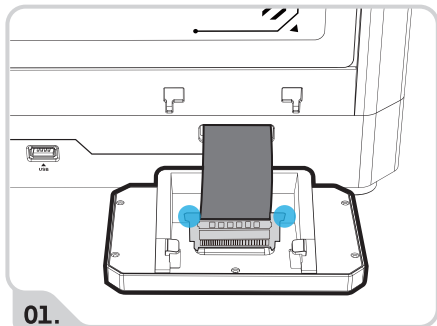

01. Insert the Flexible Printed Circuit (FPC) into the touchscreen port by pressing the terminal as pictured. Make sure the gold contacts face upwards for correct orientation.

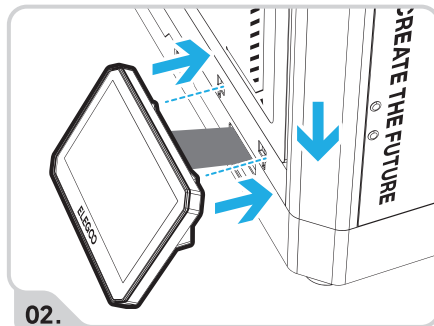

02. Insert the screen into the slot on the printer and press down to lock it in place.

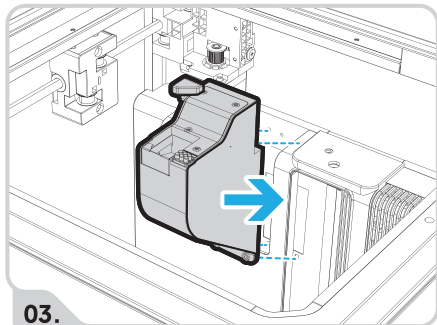

03. Align the nozzle wiper assembly with the screw holes on the rear panel.

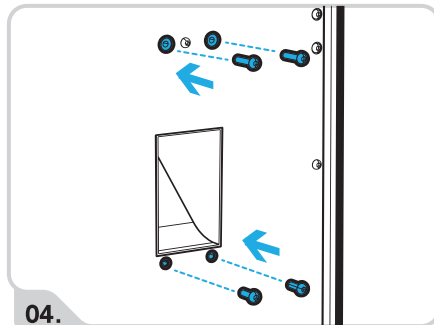

04. Secure the top with 2 FM3×12 screws and the bottom with 2 PM3×4 screws to complete the wiper assembly installation.

CANVAS Installation

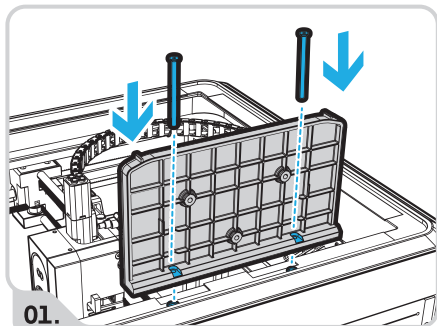

01.

Attach the CANVAS mounting bracket to the machine using 2 PM3x50 screws. (Remove any silicone plugs from the top mounting holes before installation.)

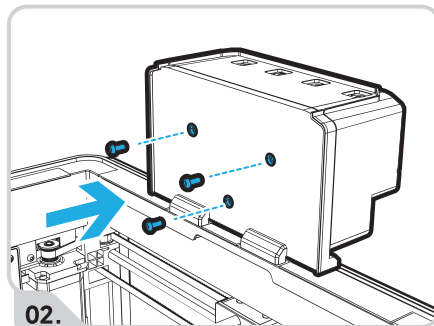

02.

Mount the CANVAS feeding module onto the bracket using 3 PM3x8 screws.

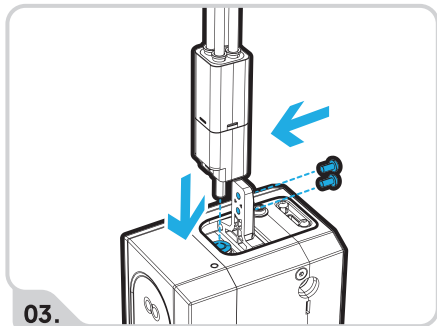

03.

Install the filament hub onto its bracket. Insert the hub's metal tube downward into the printhead's pneumatic fitting, then secure with 2 PM3x6 screws.

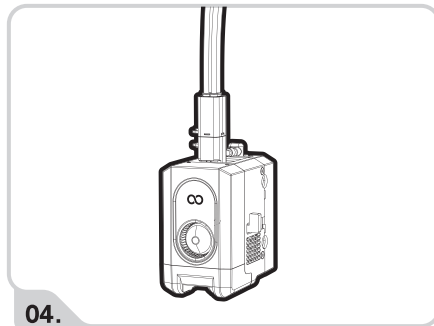

04.

The filament hub installation is now complete.

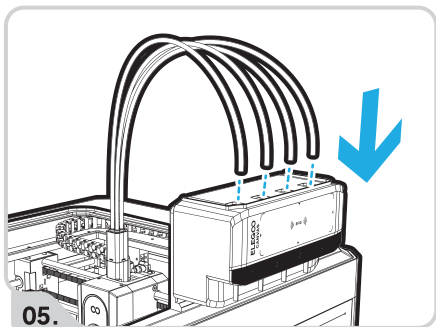

Insert one end of each PTFE tube into the four pneumatic fittings on the top of the CANVAS module.

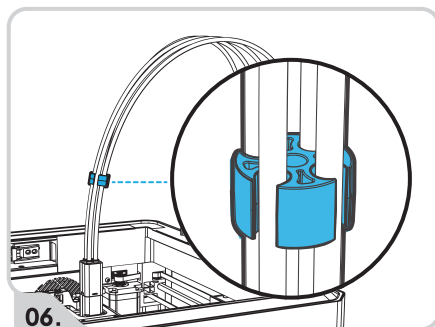

Use the clips to bundle the four tubes neatly together.

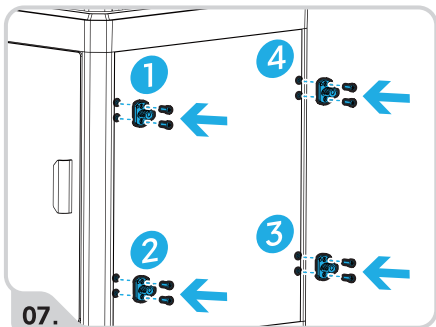

Mount the spool holder bracket to the side panel using 8 PM3×12 screws.

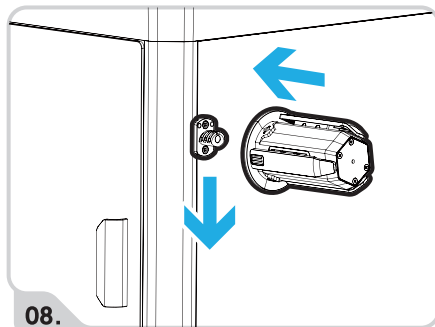

Push each spool holder down into the mounting bracket until it snaps into place. Repeat this for all four holders.

Note: Make sure each holder is installed in its designated numbered position to ensure the filament recycling function works properly.

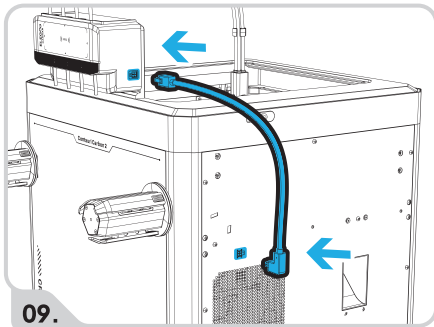

Connect the 4-pin cable: insert the angled connector into the CANVAS port on the back of the machine, and the straight connector into the 4-pin port on the right side of the CANVAS module.

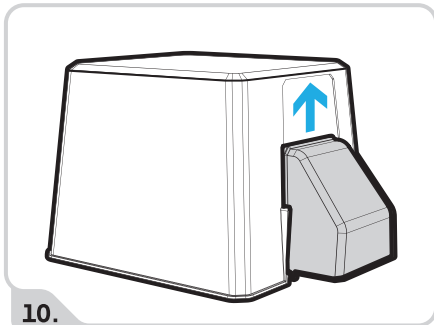

Align the extension part with the thermal cover, then push it upward until it locks into place to complete the installation of the thermal cover.

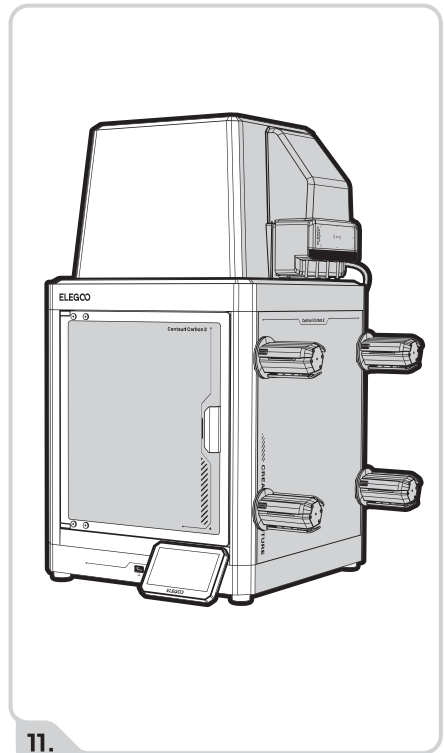

The CANVAS installation is now complete.

Filament Loading

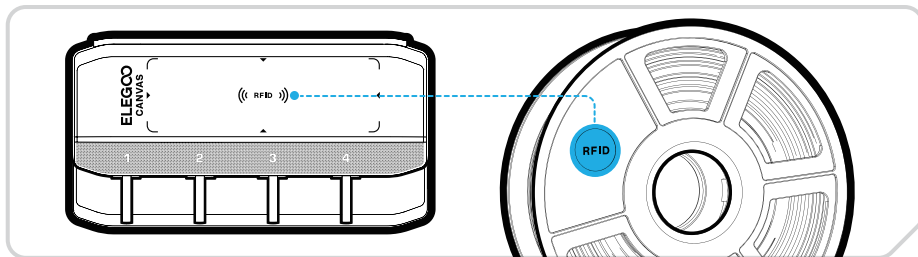

- 01.** For RFID-enabled spools, hold the tag against the recognition area on the CANVAS until you hear a confirmation beep.

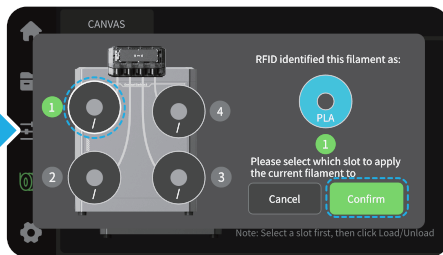
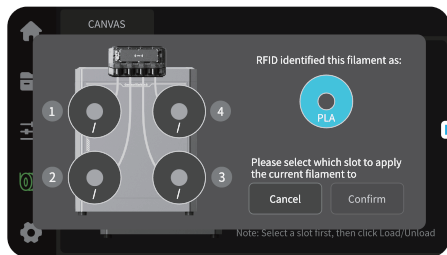

- 02.** On the touchscreen, select the corresponding number for the spool holder where the filament will be installed, then tap "Confirm" to automatically write the filament information.

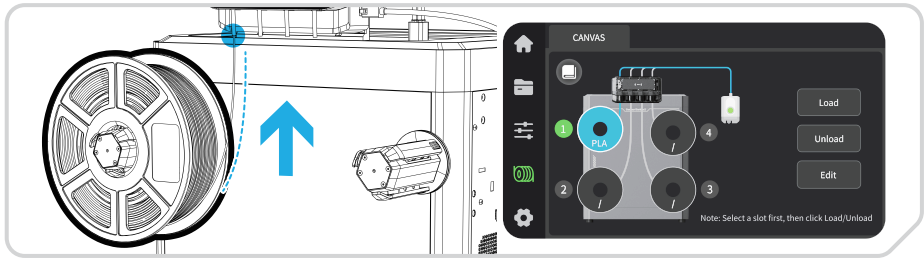

- 03.** Mount the filament spool onto its numbered holder and insert the filament into the matching inlet on the CANVAS. When the filament detection switch senses the filament, the machine will automatically feed it to the ready position.

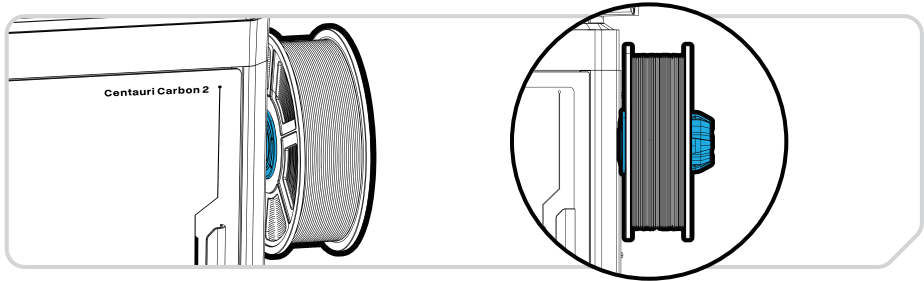

- 04.** Repeat the above steps for all filaments to be loaded.

Note:

Push the spool fully into place and seat it against the stop on the holder to prevent it from falling off or becoming tangled.

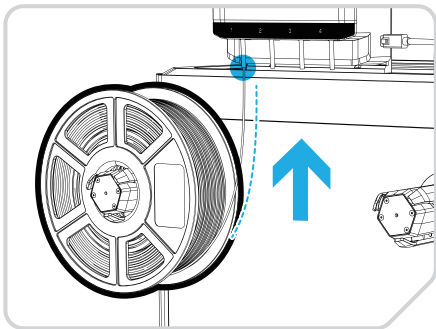

01.

For spools without RFID tags, manually enter the filament information.

02.

Enter the material details (brand, type, color) for each spool on the screen.

03.

Complete the loading for all non-RFID spools.

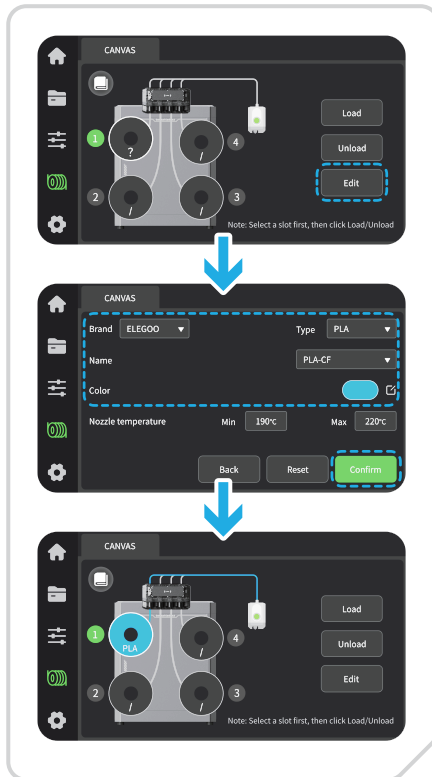

Note:

Filament with RFID tags can also be registered manually if preferred.

First Print



01.

Go to 「」 > 「Local」 and select a model to start a test print.

Tip: Long-press files on the USB flash drive to import them to local storage.

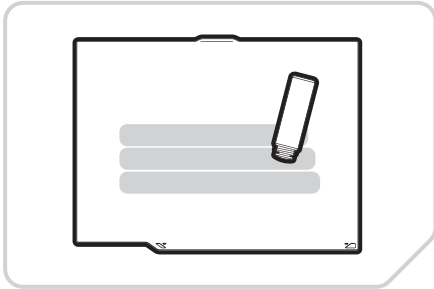

02.

To maintain optimal adhesion, regularly clean the build plate with warm water and dish soap. For even better grip, you can also apply a bed adhesive.

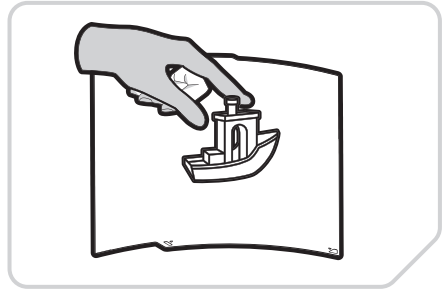

03.

After the printed model cools, remove the flexible build plate and gently bend it to release the model.

Do not over-bend the plate to avoid permanent deformation.

ElegooSlicer

Install the ElegooSlicer software from the included USB flash drive. Select the appropriate installation package for your computer system.

*Update the software if prompted after installation.

*Installation packages: .exe (Windows), x86_64.dmg (Intel Mac), arm64.dmg (M-series Mac).

01.

After successful installation, follow the setup wizard to configure your printer and filament settings.

Printer Selection

Elegoo All Clear all



Elegoo Centauri Carbon 2

- 0.4mm nozzle
- 0.2mm nozzle
- 0.6mm nozzle
- 0.8mm nozzle





Elegoo Centauri Carbon

- 0.4mm nozzle
- 0.2mm nozzle
- 0.6mm nozzle
- 0.8mm nozzle





Elegoo Centauri

- 0.4mm nozzle
- 0.2mm nozzle
- 0.6mm nozzle
- 0.8mm nozzle



Confirm Cancel

02. To slice a multicolor model:

1. Drag and drop a model file into the slicer, or click "File" in the upper-left corner to import a model.
Try one of the included sample files for your first test.
2. Click "+" on the left toolbar to add filament.
3. Set the filament type and color for each spool.
4. Select the model, then click "Color painting" in the upper right (or press N) to enter paint mode.
5. Click "Slice plate" and wait for the process to complete.

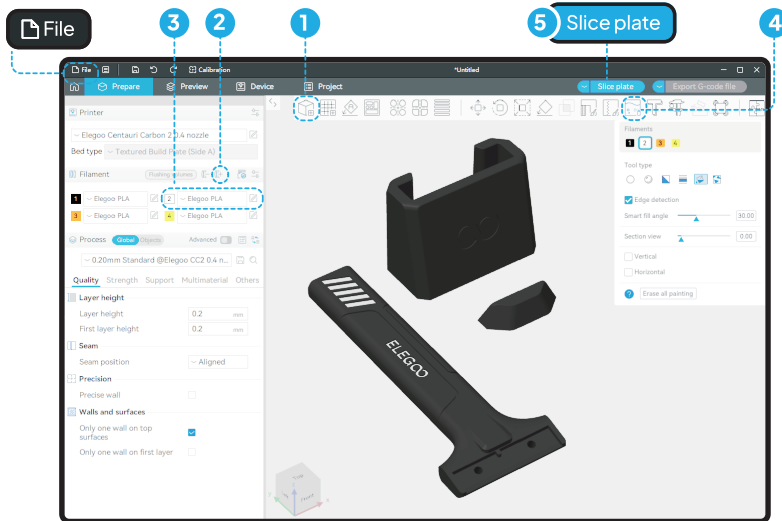

03.

When slicing is complete, click "Print" in the upper-right corner to send the file to your printer (ensure it is connected — see page 19), or select "Export G-code file" to save it to the USB flash drive for offline printing.

Print

Export G-code file

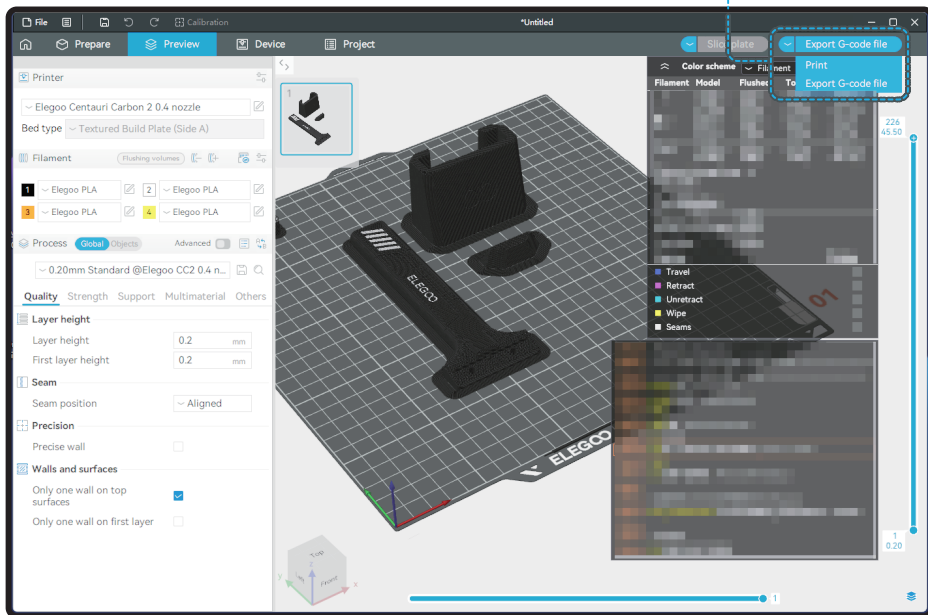

LAN (Network) Printing

01.

Connect your printer to Wi-Fi through the network settings. The assigned IP address will display once successfully connected (as shown in the right figure).

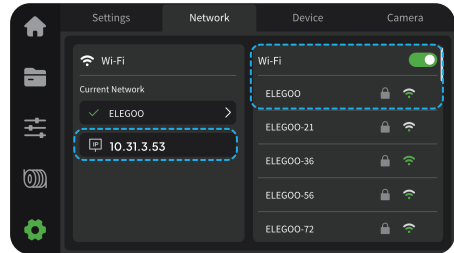

02.

Ensure your computer and printer are on the same local network. In ElegooSlicer's Device tab, click "Add Printer" (upper-right), double-click your printer from the detected devices list, and click "Connect" to complete pairing.

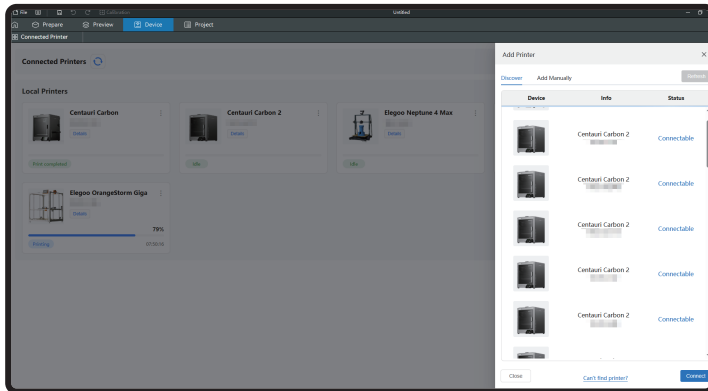

03.

Monitor print jobs directly through ElegooSlicer, where you can start, pause, or stop prints as needed.

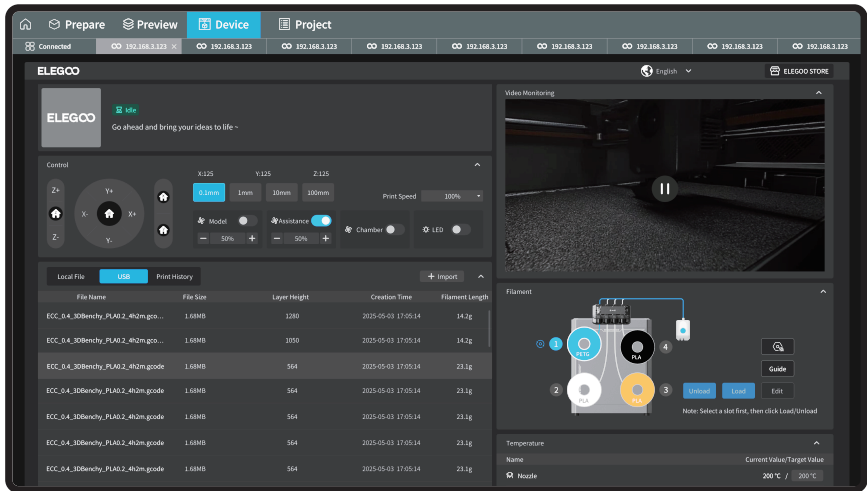

04.

For complete software instructions, please refer to the *ElegooSlicer User Manual* on the included USB flash drive.

Mainboard Connections

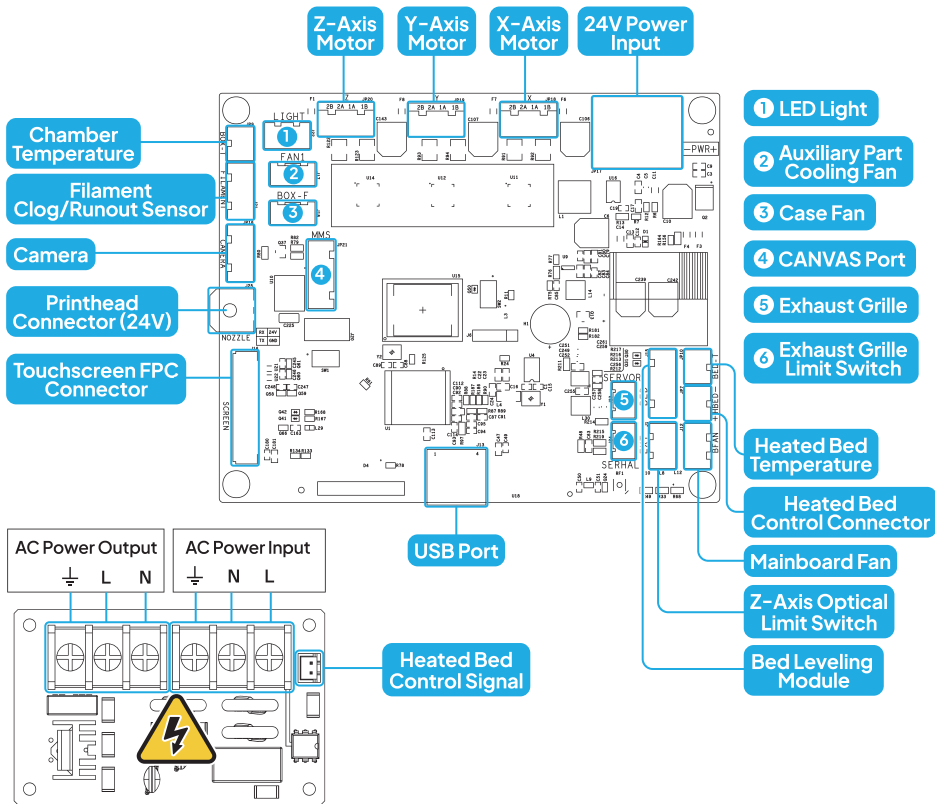

Warranty Statement

- ▶ ELEGOO printers are covered by a warranty starting from the date of receipt. Warranty periods may vary by component.

For details, please visit our Refund Policy page:
<https://www.elegoo.com/pages/refund-policy>.

- ▶ The warranty does not cover damage caused by self-disassembly, improper use, or normal wear and tear of the machine housing.

ELEGOO ▶▶

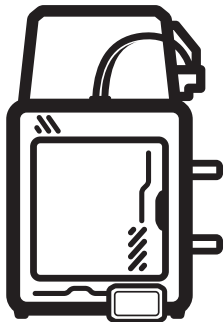

**HAPPY
PRINTING**

Create The Future ▶▶

