

User Manual

- Please refer to the included USB drive for a setup and installation instructional video.

Thank you for choosing the ELEGOO Product!

This User Manual has been provided for your convenience. Please read this instruction manual carefully before using your new printer, as the precautions, information, and tips can better help you to avoid the risk of incorrect product setup and usage.

For any questions or issues not covered in this manual, please contact us directly via our customer support email address: 3dp@elegoo.com. The ELEGOO team is always ready to provide you with quality service.

To provide you with the best product experience, in addition to this manual, you can find supplemental information for the operation of your new printer via:

- 1.The USB Drive: The digital files include a copy of this manual and all required software.
- 2.The ELEGOO official website: www.elegoo.com for related equipment operation, contact information, etc.

NOTES

1. Do not place the printer in highly vibrating or unstable environment, as machine vibrations can affect print quality.
2. Do not touch the nozzle or heated bed while the printer is in operation to avoid burns and personal injury from high temperatures.
3. After printing, promptly utilize the residual heat in the nozzle to effectively clean the filament residue using a suitable tool. Avoid direct contact with the nozzle to prevent potential burns.
4. When printing low-temperature filaments such as PLA and flexible filaments, please remove the glass top cover.
5. We recommend using ELEGOO's slicing software to ensure the proper functioning of the machine and achieve optimal printing results.
6. Perform regular maintenance on the printer by cleaning the machine body with a dry cloth to remove dust and any sticky filament residue. Ensure the printer is powered off before cleaning.
7. Regularly check and clean the printer's cooling fans to prevent debris buildup and extend their lifespan.
8. Be cautious of the machine's high-speed moving parts to avoid any potential pinch hazards.
9. The Z-axis of the machine utilizes lead screws for its moving parts. Apply lubricating oil as needed to ensure smooth movement.
10. Children must be supervised by adults when using the machine to avoid personal injury.
11. In case of an emergency, directly turn off the power.
12. Ensure the machine is properly grounded for safe operation. Failure to properly ground or neglecting to ground the machine can increase the risk of electrical leakage.
13. If the machine is not in use for an extended period, please turn off the power and unplug the power cord.

Contents

Machine Parameters _____	1
Component Introduction _____	2
Accessory Specification _____	3
Machine Setup & Installation _____	4
Screen Operation Instruction _____	6
First Print _____	8
Filament Replacement _____	9
Slicing Software _____	10
LAN (Network) Printing _____	12
Mainboard Circuit Wiring Diagram _____	13

Printer Specifications

Printer Type: FDM (Fused Deposition Modeling)

Maximum Build Volume: 256*256*256(mm³)

Print Precision: ±0.1mm

Nozzle Diameter: Standard (0.4mm)

Print Speed: ≤500mm/s

Ambient Environment Temperature: 5°C~40°C

Operating Temperature Specifications

Maximum Temperature of Nozzle: 320°C

Maximum Temperature of Heated Bed: 110°C

Software Specifications

Slicer Software: ELEGOO Slicer (recommended)

Input File Format: STL, OBJ, 3MF, STP

Output File Format: G-code

Interface: USB Drive, WIFI

Power Supply Specifications

Input Power: AC 100-240V; 50/60Hz

Rated Power: 1100W@220V 350W@110V

Physical Specifications

Machine Size: 398*404*490mm

Net Weight: 17.5kg

Component Introduction

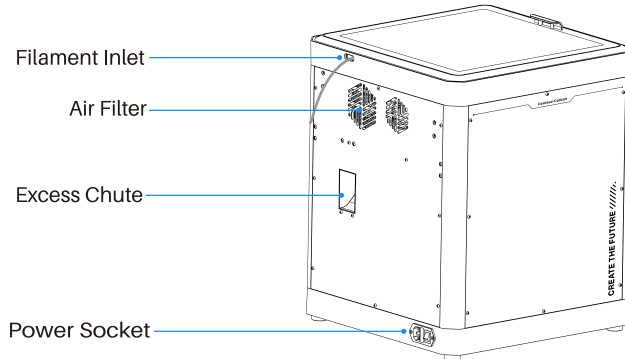
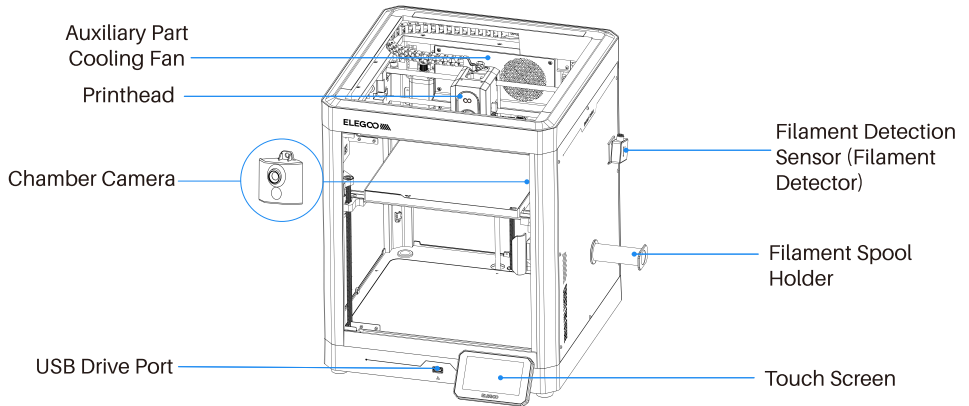

Accessory Specification



Touch Screen

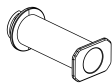

Spool Holder



Filament Sample

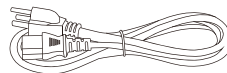

Power Cord



Unclogging
Pin Tool



(1.5/2.0/2.5/3.0mm)
Allen Wrench

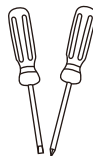

Screwdriver



Spare Heatbed
Nozzle Wiper



USB Drive



Scraper Blade



User Manual

Machine Setup & Installation



Scan to access tutorials

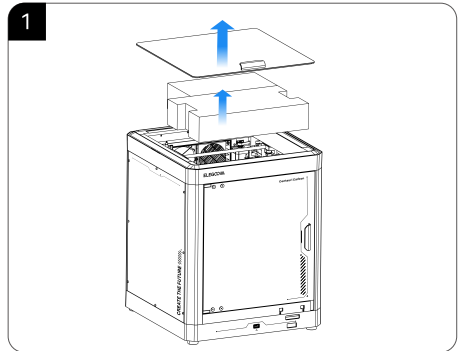

1. Take out the foam and tool kit from the printer.

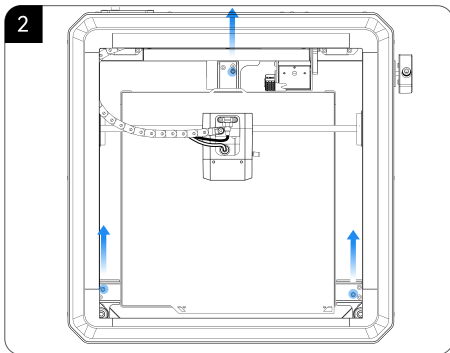

2. Unlock the heated bed and use an Allen wrench to remove the three screws in the picture.

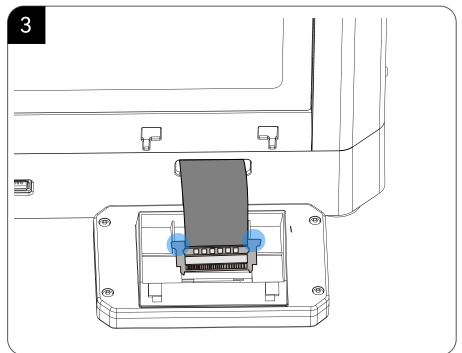

3. Insert the ribbon cable into the port by pressing the terminal as pictured. Make sure the gold contacts on the ribbon cable face upwards.

Machine Setup & Installation

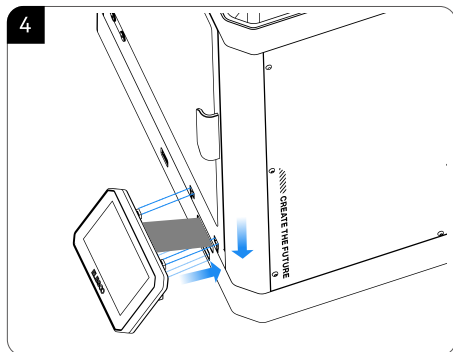

4. Install the screen into the corresponding slot on the printer and push it down to lock it in place.

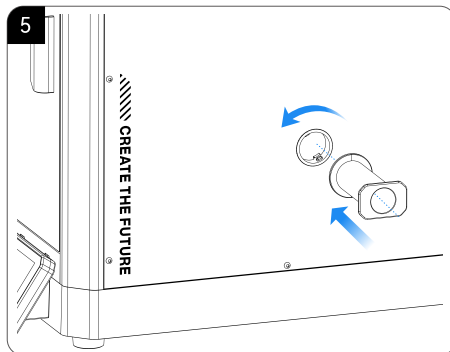

5. Mount the spool holder onto the hole on the right side of the machine and secure it by turning counterclockwise.

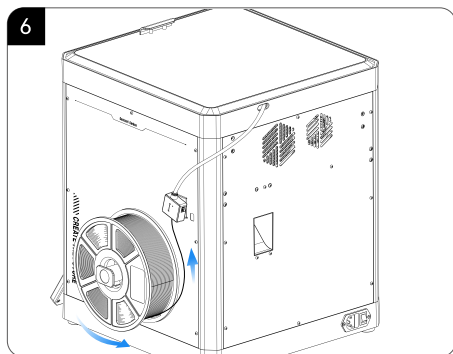

6. Load the filament by inserting one end into the filament detector and pushing it forward until it reaches its maximum position.



Important note: If you have disassembled machine components such as the nozzle assembly or build platform, make sure to re-level the platform before printing.

Screen Operation Instruction

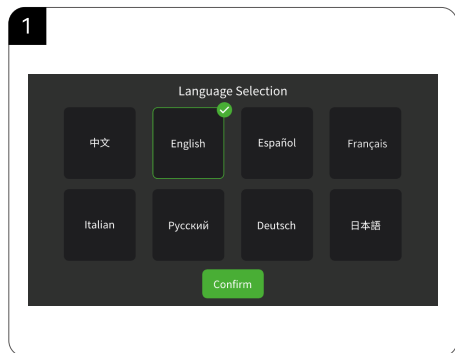

1. Language Selection

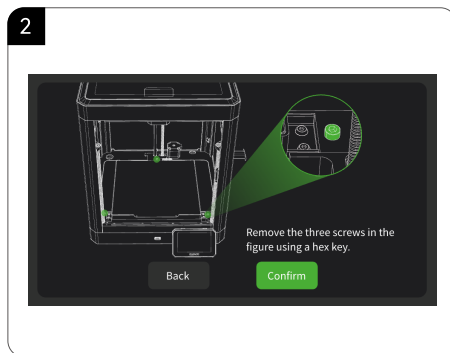

2. Follow the on-screen prompt to remove the three fixed screws of the build platform.

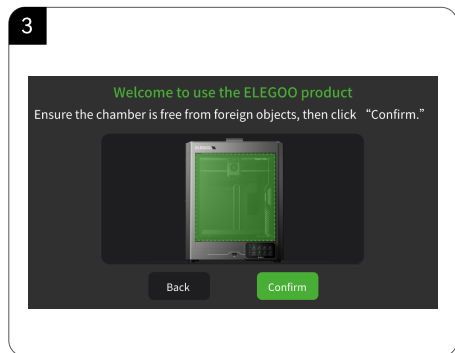

3. Ensure the printer chamber is free from foreign objects, then click "Confirm" to proceed.

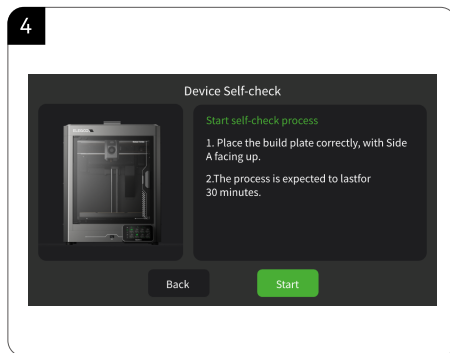

4. Enter the initial self-check process. Vibrations and noises during the self-check are normal.

Screen Operation Instruction

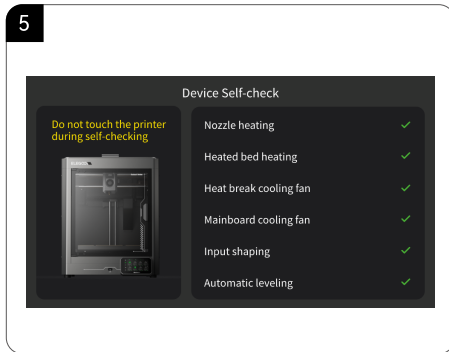

5. Do not tap or shake the machine during the self-check process to avoid error prompts.

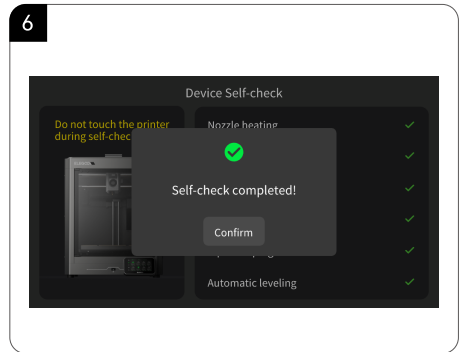

6. Self-check completed. Click "Confirm" to proceed.



Note: Ensure to recalibrate the printing platform before each print when switching sides on the double-sided textured flexible plate.

First Print

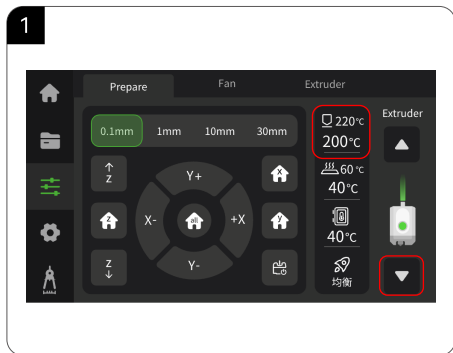

1. Click - to set the nozzle temperature to the suitable temperature for the filament (e.g., 220°C for PLA). Wait for the temperature to reach the set value, then click repeatedly until the filament starts extruding from the nozzle.

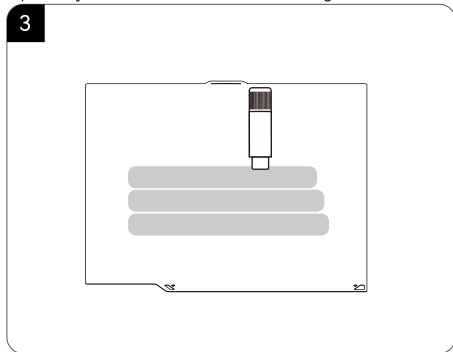

3. If the adhesion of the build plate decreases after prolonged use, you can apply solid glue or use platform adhesive spray to enhance the first-layer adhesion of the model, or replace the build plate.

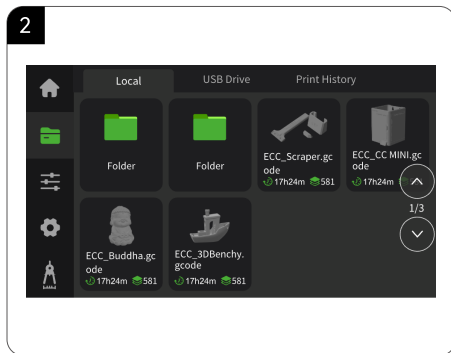

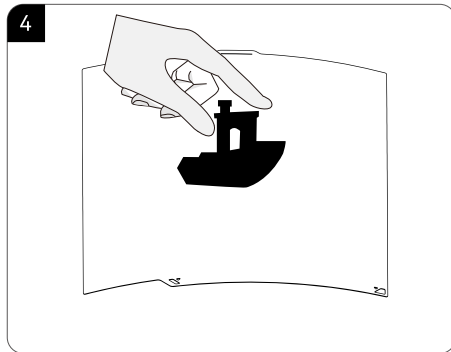

2. Click - [Local] to select a model for test printing. (Tip: Long press to import print files from your USB drive to local storage.)

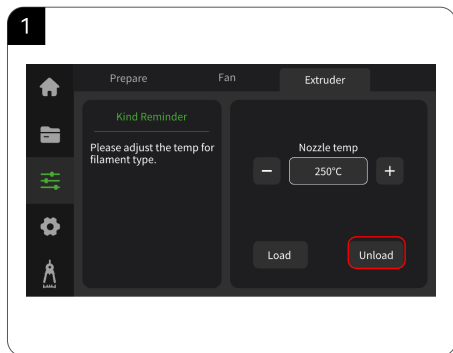

4. After the printed model cools down, detach the flexible build plate together with the model from the device. Bend the plate slightly to separate the model from it (avoid overbending to prevent deformation).

Filament Replacement



1. Click  and switch to the Extruder option. Click “Unload” and wait for the machine to complete the unloading process.

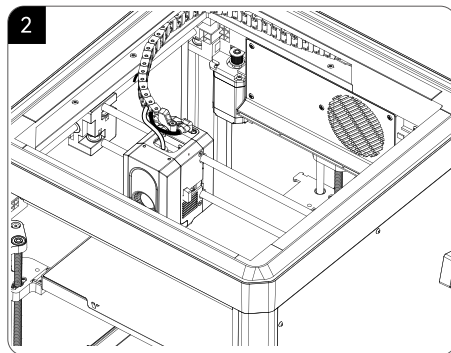

2. After unloading is complete, extract the old filament from the tube and replace it with a new one.

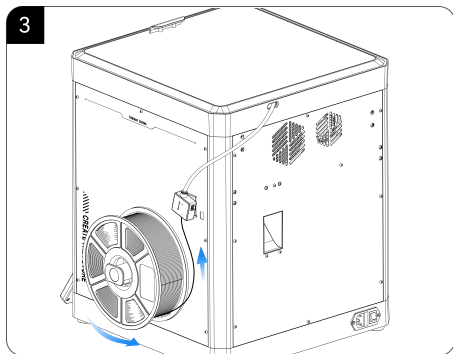

3. Load the filament by inserting one end into the filament detector and pushing it forward until it reaches its maximum position.

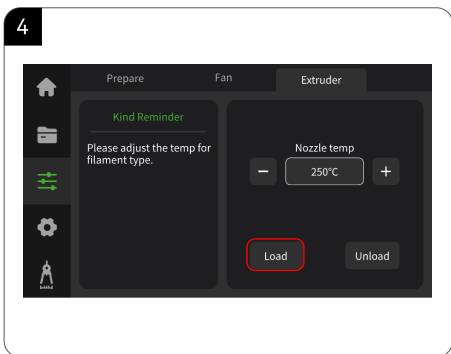

4. Click “Load” and wait for the nozzle to heat up. Once the nozzle reaches the preset temperature, it will start the filament loading process.

Slicing Software

The included USB drive contains slicing software for installation and use.

* Select your printer model before starting the slicing process.

Printer Selection

Elegoo All Clear all



Elegoo Centauri Carbon

- 0.4mm nozzle
- 0.2mm nozzle
- 0.6mm nozzle
- 0.8mm nozzle





Elegoo OrangeStorm Giga

- 0.6mm nozzle
- 0.4mm nozzle
- 0.8mm nozzle
- 1.0mm nozzle





Elegoo Neptune 4 Max

- 0.4mm nozzle
- 0.2mm nozzle
- 0.6mm nozzle
- 0.8mm nozzle
- 1.0mm nozzle



Confirm Cancel

Slicing Software

- 1.Importing model for slicing: You can simply drag and drop the model file into the slicing software or click "File" in the top left corner and select "Import."
- 2.Exporting G-code file: You can use the web interface to send the generated G-code file directly to the printer for online printing or save it to a USB drive for offline printing.

The screenshot displays a 3D slicing software interface. On the left, a settings panel is visible with sections for Printer (Elegoo Centauri Carbon 0.4 nozzle), Bed type (Smooth PEI Plate / High Temp Plate), Filament (Elegoo PLA), Process (Global Objects, Advanced), Quality (Strength, Support, Others), Layer height (0.2 mm), Seam (Aligned), Precision (Precise wall checked), and Walls and surfaces (Only one wall on top surfaces checked). The main workspace shows a 3D model of a boat with a red top surface. On the right, a 'Slice plate' view shows a vertical stack of layers with a 'Line Type' table. Below the table is a 'Total estimation' section and a G-code preview.

Line Type	Time	Percent	Used filament	Display
Inner wall	7m58s	20.8%	0.94 m 2.83 g	
Outer wall	11m16s	29.3%	0.97 m 2.93 g	
Overhang wall	4s	0.2%	0.01 m 0.02 g	
Sparse infill	3m27s	9.0%	0.33 m 1.59 g	
Internal solid infill	4m0s	10.4%	0.51 m 1.83 g	
Top surface	1m18s	3.4%	0.12 m 0.39 g	241
Bottom surface	20s	0.9%	0.01 m 0.04 g	
Bridge	35s	1.5%	0.05 m 0.14 g	
Internal Bridge	1m0s	2.6%	0.17 m 0.52 g	
Gap infill	3m32s	9.2%	0.22 m 0.66 g	
Custom	11s	0.5%	0.04 m 0.12 g	
Travel	4m40s	12.2%		
Retract				
Unretract				
Wipe				
Seams				

Total estimation
Total Filament: 3.67 m 11.03 g
Model Filament: 3.67 m 11.03 g
Cost: 0.00
Prepare time: 6s
Model printing time: 38m17s
Total time: 38m25s

```
91957 M106 S255 ;Cooling nozzle
91958 M83
91959 G02 E0 ;zero the extruder
91960 G2 J10 Z48.5 E-1 F3000 ;lower z a little
91961 G90
91962 ;if necessary Perform the cut fl...
```

LAN (Network) Printing

1. The device supports Wi-Fi connection. Go to the “Network” interface, establish a successful connection, and check the IP address on the screen (refer to the image on the right).

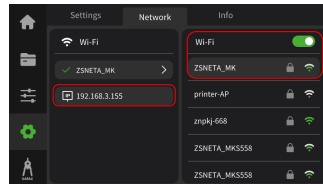

2. Connect your computer and printer to the same local area network (LAN). Open your browser and enter the printer's IP address in the address bar to access the backend management. Utilize the web interface to monitor the printing progress and pause/stop the print as needed.

*Upload G-code files for printing.

The name of the file	State	Start time	Total consumption	File size
ECC_04_3DBenchy_PLA02_4h2m.gco...	Cancel	2023-10-12 08:19:48	12923m43s	23.17MB
ECC_04_3DBenchy_PLA02_4h2m.gco...	Finish	2023-10-12 08:19:48	12923m43s	23.17MB
ECC_04_3DBenchy_PLA02_4h2m.gcode	Finish	2023-10-12 08:19:48	12923m43s	23.17MB
ECC_04_3DBenchy_PLA02_4h2m.gcode	Finish	2023-10-12 08:19:48	12923m43s	23.17MB
ECC_04_3DBenchy_PLA02_4h2m.gcode	Finish	2023-10-12 08:19:48	12923m43s	23.17MB
ECC_04_3DBenchy_PLA02_4h2m.gcode	Finish	2023-10-12 08:19:48	12923m43s	23.17MB
ECC_04_3DBenchy_PLA02_4h2m.gcode	Finish	2023-10-12 08:19:48	12923m43s	23.17MB
ECC_04_3DBenchy_PLA02_4h2m.gcode	Finish	2023-10-12 08:19:48	12923m43s	23.17MB

Name	Current value / Target value
Nozzle	200 °C / 200 °C
Warm bed	200 °C / 200 °C
Box	200 °C / 200 °C

Select all	The name of the file	File size	Start time	Video duration
<input type="checkbox"/>	XXXXXXXXXXXXXXXXXXXXXXXXXXXX...	3.6MB	2023-11-31 14:40:07	43s
<input type="checkbox"/>	XXXXXXXXXXXXXXXXXXXXXXXXXXXX.MP4	3.6MB	2023-11-31 14:40:07	43s
<input type="checkbox"/>	XXXXXXXXXXXXXXXXXXXXXXXXXXXX.MP4	3.6MB	2023-11-31 14:40:07	43s
<input type="checkbox"/>	XXXXXXXXXXXXXXXXXXXXXXXXXXXX.MP4	3.6MB	2023-11-31 14:40:07	43s

Mainboard Circuit Wiring Diagram

 Type-C Interface (24V): It is strictly prohibited to directly connect this port to a computer or external devices, as it may result in damage.

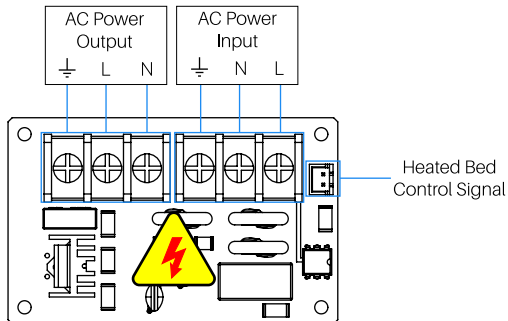
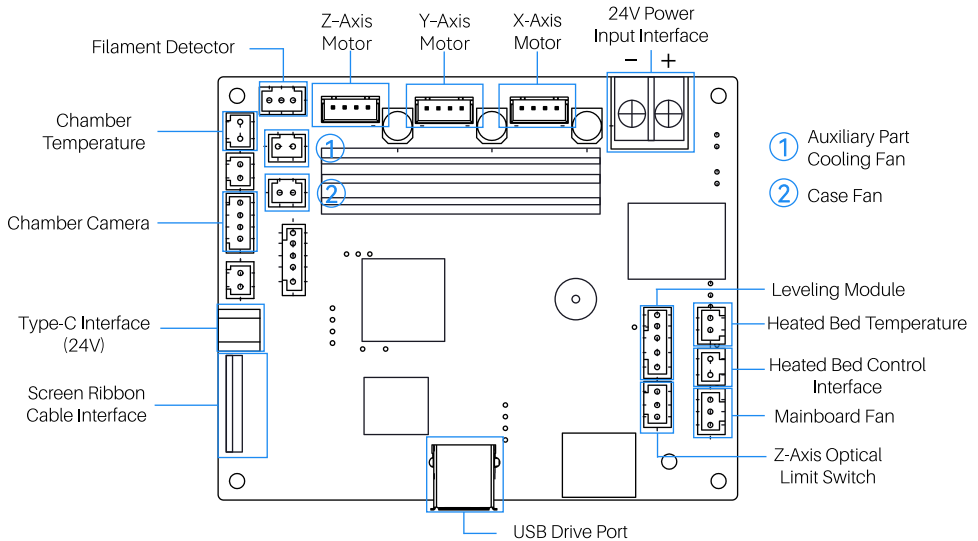

Warranty Statement

- ELEGOO printers are covered by a warranty from the date of receipt. Warranty periods for different components may vary. For more details, please visit our website (<https://www.elegoo.com/pages/refund-policy>).
- The free warranty does NOT include problems caused by self-disassembly and improper use, and wear and tear of the machine housing, etc.

After-sales service registration card

Date of purchase: _____

Place of purchase: _____

Printer: _____

S/N: _____

Fault description:

Contact: _____

Address: _____

Phone number: _____



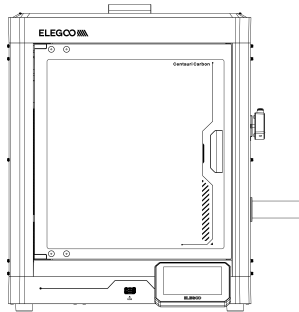

ELEGOO official website: www.elegoo.com

Happy Printing!